

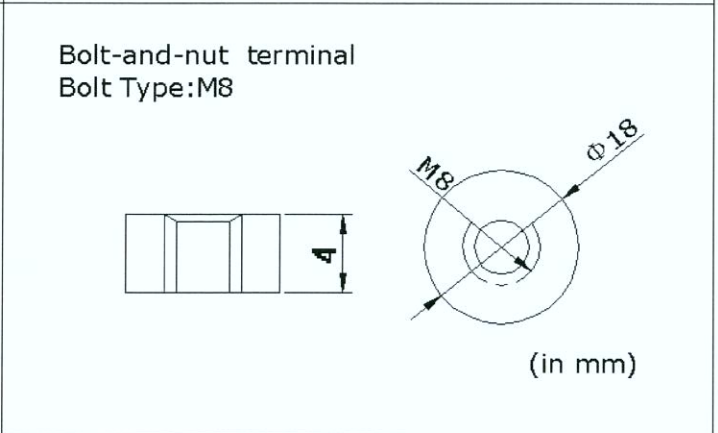

# FLG 12-100

## PHYSICAL SPECIFICATION

Nominal Voltage		12V
Nominal Capacity (20Hr)		100Ah
Dimension	Length	331 ±2mm
	Width	172 ±2mm
	Container Height	214 ±2mm
	Total Height	220 ±2mm
Drawing 400331-0		Weight 31.5 Kg ± 5%
Standard Terminal		Bolt Type: M8

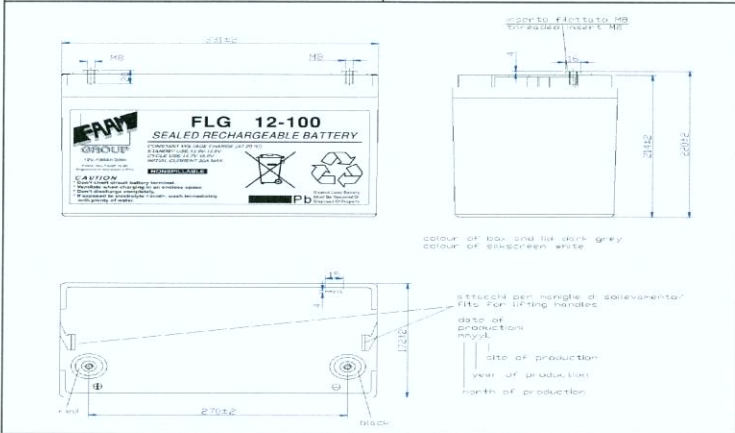

## ELECTRICAL SPECIFICATION

Characteristics		
Capacity	20 hour rate	100,00Ah
	10 hour rate	85,00Ah
	5 hour rate	73,50Ah
	3 hour rate	65,43Ah
	1 hour rate	44,61Ah
Capacity affected by temperature	40°C	102%
	20°C	100%
	0°C	85%
Internal Resistance 5 mΩ ±10%		SCC 2150 A ±10%
Constant Voltage Charge	Cycle	Initial Charging Current less than 30 A Voltage 14,4~15,0V at 20°C Temperature Coefficient -30 mV/°C
	Stand by	No limit on Initial Charging Current Voltage 13,5~13,8V at 20°C Temperature Coefficient -20 mV/°C

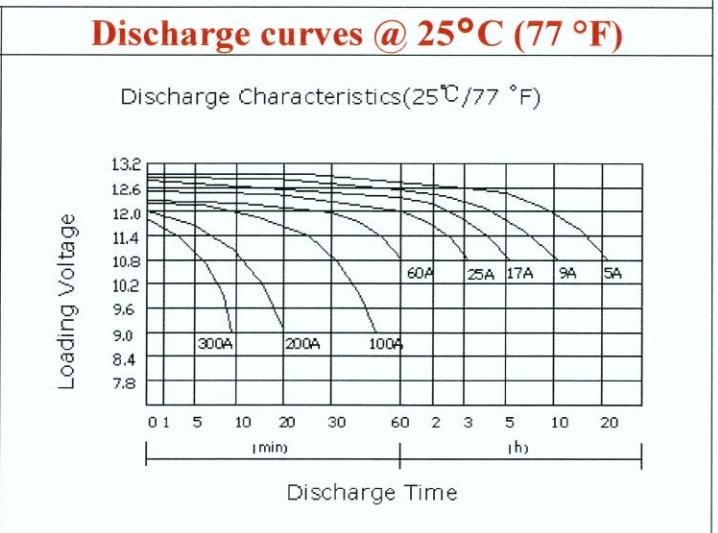

## Constant Current(Amp) and Constant Power (Watt/Cell) Discharge Table at 25°C

Time		5min	15min	30min	60min	90min	120min	180min	300min	480min	600min
9.9V	A	128,62	91,22	63,85	54,02	42,80	36,18	21,86	14,99	10,34	8,93
	W	368,33	276,90	182,48	117,32	95,04	71,60	47,16	32,39	24,22	20,27
10.2V	A	116,88	90,28	61,94	44,35	35,14	29,70	21,81	14,93	10,30	8,79
	W	358,24	268,05	176,81	113,67	92,08	69,38	46,88	32,20	24,07	20,23
10.8V	A	93,88	78,64	58,85	43,32	34,32	29,01	21,57	14,70	10,13	8,50
	W	336,37	252,88	166,80	107,24	86,87	65,45	45,96	31,56	23,60	19,83

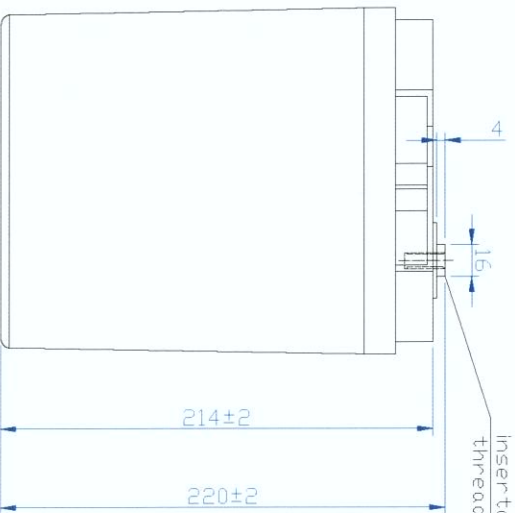
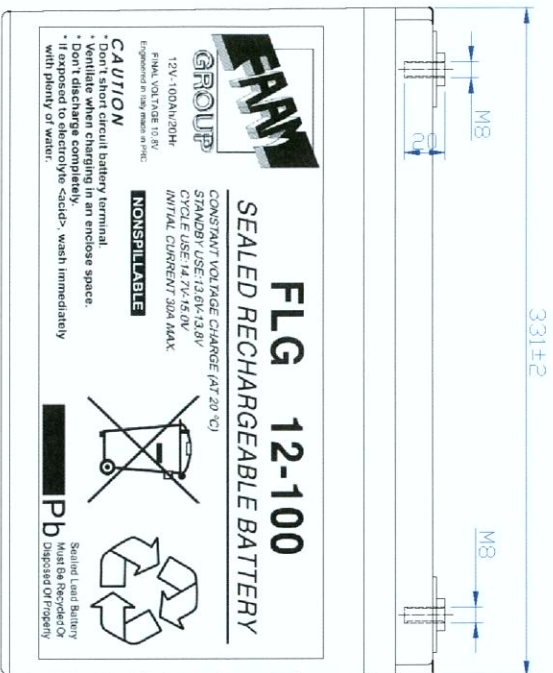

date of  
production:  
mmyyL  
|  
site of production  
|  
year of production  
|  
month of production

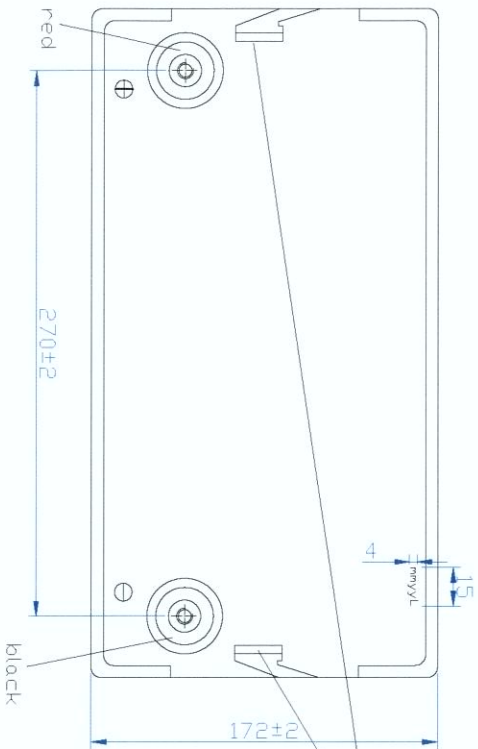

attacchi per maniglie di sollevamento/  
fits for lifting handles

colour of box and lid: dark grey  
colour of silkscreen: white

REV.	DATE	PROGETTISTA/DESIGNER	DISEGNO/DRAWN	APPROVATO/APPROVED	DESCRIZIONE MODIFICAZIONE/REVISIONE
INDICAZIONE GENERALE/GENERAL INDICATION		MATERIALE/MATERIAL		REVISIONE	DIREZIONE/ADDRESS
GRADO DI PRECISIONE/TOLERANCE OR ACCURACY		ABS PVO Pb/Ca		R. PARENTI	
NORMA UNI 6507/STANDARD UNI 6507		PRODOTTO GENERALE/COMPRESSO/GENERAL PLANT/PLANT NAME		S. BALDASSARRI	
SINTESI DELLE APPLICAZIONI		SISTEMI DI APPLICAZIONE SIM		APPROVATO/APPROVED	
SCALE/SCALE		FOGLIO/FOLIO		R. ISIDORI	
1:2.5		A3		4 00331.dwg	
BATTERIA STAZIONARIA COD. FIG. 12-100 12V 100AH/20h gel/ STATIONARY BATTERY CODE FIG. 12-100 12V 100AH/20h gel		CODICE/COE		VERSIONE/VERSION	
		FIG. 12-100		SERIES GEL	
		TIPICO/TYP		CARICA/CHARGE	
		01.03.2011		DATA/DATE	
		1		REVISIONI R-REV/ DRAWING R-REV	
		1		TAV.	



FAAM S.P.A. Via Monti,11 63026 Monterubbiano (AP) ITALY  
Tel. ++39/073942581 Fax. ++39/07394258229 www.faam.com

Questo disegno è di proprietà della FAAM e non può essere riprodotto o reso noto senza autorizzazione scritta.  
This drawing is a proprietary and shall not be reproduced or released to otherwise authorized by FAAM.



12V-100Ah/20Hr

FINAL VOLTAGE 10,8V

Engineered in Italy made in PRC

**CAUTION**

- \* Don't short circuit battery terminal.
- \* Ventilate when charging in an enclosed space.
- \* Don't discharge completely.
- \* If exposed to electrolyte <acid>, wash immediately with plenty of water.

# FLG 12-100

## SEALED RECHARGEABLE BATTERY

CONSTANT VOLTAGE CHARGE (AT 20 °C)

STANDBY USE: 13.6V-13.8V

CYCLE USE: 14.7V-15.0V

INITIAL CURRENT 30A MAX.

**NONSPILLABLE**



**Pb**

Sealed Lead Battery  
Must Be Recycled Or  
Disposed Of Properly