

Axpert VM II Off-Grid Inverter

Operation without battery



- Pure sine wave solar inverter
- Output power factor 1
- High PV input voltage range
- Battery independent design
- Built-in 100A MPPT solar charger
- Battery equalization function to optimize battery performance and extend lifecycle
- Built-in anti-dust kit for harsh environment
- Dual outputs selected as either programmable output or generator input

Axpert VM II Off-Grid Inverter Selection Guide

MODEL	Axpert VM II 3000-24	Axpert VM II 5000-48
Rated Power	3000VA / 3000W	5000VA / 5000W
INPUT		
Voltage	230 VAC	
Selectable Voltage Range	170-280 VAC (For Personal Computers) ; 90-280 VAC (For Home Appliances)	
Frequency Range	50 Hz/60 Hz (Auto sensing)	
OUTPUT		
AC Voltage Regulation (Batt. Mode)	230VAC \pm 5%	
Surge Power	6000VA	10000VA
Efficiency (Peak)	90% ~ 93%	
Transfer Time	10 ms (For Personal Computers) ; 20 ms (For Home Appliances)	
Waveform	Pure sine wave	
Dual Outputs	Yes	
BATTERY		
Battery Voltage	24 VDC	48 VDC
Floating Charge Voltage	27 VDC	54 VDC
Overcharge Protection	33 VDC	63 VDC
SOLAR CHARGER & AC CHARGER		
Maximum PV Array Open Circuit Voltage	500 VDC	500 VDC
Maximum PV Array Power	4000 W	5000 W
MPP Range @ Operating Voltage	120~450 VDC	120~450 VDC
Maximum Solar Charge Current	100 A	100 A
Maximum AC Charge Current	100 A	100 A
Maximum Charge Current	100 A	100 A
PHYSICAL		
Dimension, D x W x H (mm)	100 x 300 x 440	
Net Weight (kgs)	9	10
Communication Interface	USB/RS232	
ENVIRONMENT		
Humidity	5% to 95% Relative Humidity (Non-condensing)	
Operating Temperature	-10°C to 50°C	
Storage Temperature	-15°C to 60°C	

Product specifications are subject to change without further notice.

Tiger Neo N-type 54HL4-(V) 410-430 Watt MONO-FACIAL MODULE

N-Type

Positive power tolerance of 0~+3%

IEC61215(2016), IEC61730(2016)

ISO9001:2015: Quality Management System

ISO14001:2015: Environment Management System

ISO45001:2018

Occupational health and safety management systems

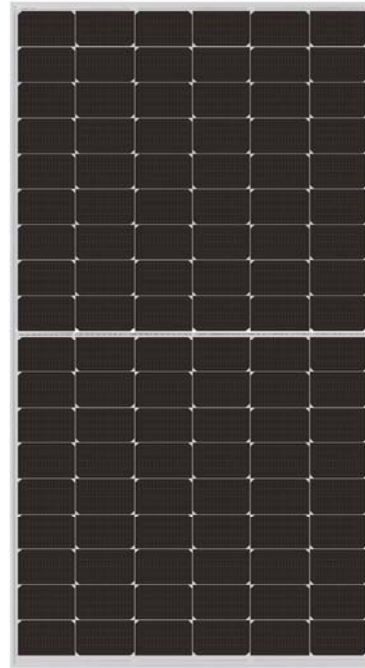

Key Features



SMBB Technology

Better light trapping and current collection to improve module power output and reliability.



PID Resistance

Excellent Anti-PID performance guarantee via optimized mass-production process and materials control.



Durability Against Extreme Environmental Conditions

High salt mist and ammonia resistance.



Hot 2.0 Technology

The N-type module with Hot 2.0 technology has better reliability and lower LID/LETID.



Enhanced Mechanical Load

Certified to withstand: wind load (2400 Pascal) and snow load (5400 Pascal).



LINEAR PERFORMANCE WARRANTY

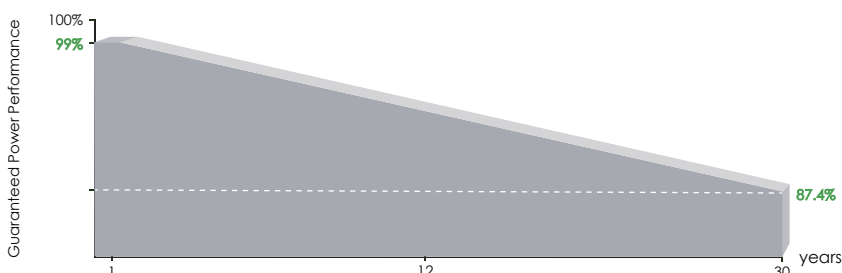

15 Year Product Warranty

30 Year Linear Power Warranty

0.40% Annual Degradation Over 30 years

Engineering Drawings

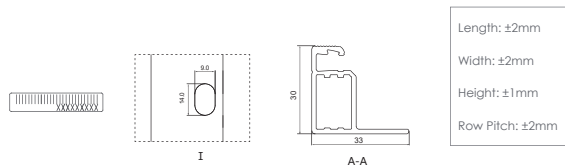
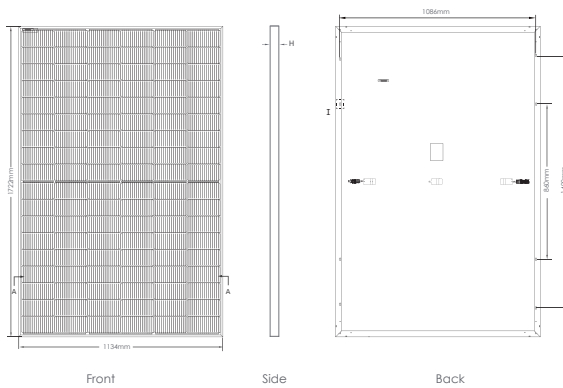

Packaging Configuration

(Two pallets = One stack)

36pcs/pallets, 72pcs/stack, 936pcs/ 40'HQ Container

Electrical Performance & Temperature Dependence

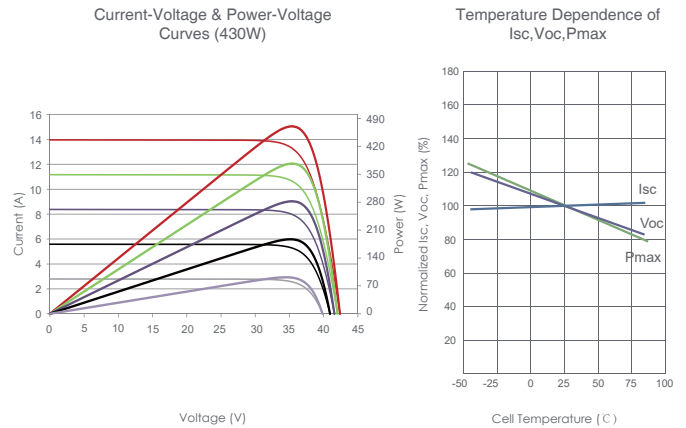

Mechanical Characteristics

Cell Type	N type Mono-crystalline
No. of cells	108 (6×18)
Dimensions	1722×1134×30mm (67.79×44.65×1.18 inch)
Weight	22 kg (48.50 lbs)
Front Glass	3.2mm, Anti-Reflection Coating, High Transmission, Low Iron, Tempered Glass
Frame	Anodized Aluminium Alloy
Junction Box	IP68 Rated
Output Cables	TUV 1×4.0mm ² (+): 400mm, (-): 200mm or Customized Length

SPECIFICATIONS

Module Type	JKM410N-54HL4		JKM415N-54HL4		JKM420N-54HL4		JKM425N-54HL4		JKM430N-54HL4	
	STC	NOCT	STC	NOCT	STC	NOCT	STC	NOCT	STC	NOCT
Maximum Power (Pmax)	410Wp	308Wp	415Wp	312Wp	420Wp	316Wp	425Wp	320Wp	430Wp	323Wp
Maximum Power Voltage (Vmp)	31.13V	29.06V	31.32V	29.21V	31.51V	29.34V	31.70V	29.50V	31.88V	29.63V
Maximum Power Current (Imp)	13.17A	10.61A	13.25A	10.68A	13.33A	10.76A	13.41A	10.83A	13.49A	10.91A
Open-circuit Voltage (Voc)	37.73V	35.84V	37.92V	36.02V	38.11V	36.20V	38.30V	36.38V	38.49V	36.56V
Short-circuit Current (Isc)	13.91A	11.23A	13.99A	11.29A	14.07A	11.36A	14.15A	11.42A	14.23A	11.49A
Module Efficiency STC (%)	21.00%		21.25%		21.51%		21.76%		22.02%	
Operating Temperature(°C)	-40°C~+85°C									
Maximum system voltage	1000/1500VDC (IEC)									
Maximum series fuse rating	25A									
Power tolerance	0~+3%									
Temperature coefficients of Pmax	-0.29%/°C									
Temperature coefficients of Voc	-0.25%/°C									
Temperature coefficients of Isc	0.045%/°C									
Nominal operating cell temperature (NOCT)	45±2°C									

*STC: Irradiance 1000W/m² Cell Temperature 25°C AM=1.5
 NOCT: Irradiance 800W/m² Ambient Temperature 20°C AM=1.5 Wind Speed 1m/s

Battery Pack Parameters

No.	Items	General Parameter		Remark
1	Combination method	15S		
2	Nominal Voltage	48V		
3	Rated Capacity	Typical	100Ah	
		Minimum	100Ah	
4	Energy	4800Wh		
5	Factory Voltage	48~51V		Mean Operation Voltage
6	Voltage at end of Discharge	37.5~42V		Discharge Cut-off Voltage
7	Voltage at end of Charge	52.5~55.5V		Charge Cut-off Voltage
8	Standard charge	Constant Current 20A Constant Voltage see No.7 0.02CA cut-off		Charge time : Approx 5~6 h
9	Limiting current	20A		BMS Limited (Charge current is $\geq 100A$ to open the current Limit)
10	Standard discharge	Constant current: 20A end voltage see NO.6		
11	Maximum Continuous Charge Current	100A		$50^{\circ}C \geq T \geq 5^{\circ}C$
12	Maximum Continuous Discharge Current	100A		$55^{\circ}C \geq T \geq 0^{\circ}C$
13	Operation Temperature Range	Charge: $0 \sim 55^{\circ}C$		$60 \pm 25\%R.H.$ No matter what mode the battery is in, once the temperature is found to exceed the absolute temperature range, stop charging or discharging immediately
		Discharge: $-20 \sim 60^{\circ}C$		
14	Storage Temperature Range	Less than 6 months: $-10 \sim 35^{\circ}C$		$60 \pm 25\%R.H.$ at the shipment state
		Less than 3 months: $-10 \sim 45^{\circ}C$		
		Less than 1 months: $-20 \sim 55^{\circ}C$		
15	Dimensions(W*D*H)	442*480*178mm		Include case
16	Net Weight	46Kg		Include case
17	Internal Impedance	$\leq 45m\Omega$		Internal resistance measured at AC 1KHz after 50% charge. The measure must uses the new batteries that within one week after shipment and cycles less than 5 times.

Battery Management System

Function	
Cell over-charge voltage	Cell charge low temperature
Cell over-discharge voltage	Cell charge over temperature
Pack over-charge voltage	Cell discharge low temperature

Alarm	Pack over-discharge voltage	Cell discharge over temperature
	Over-current charge	Environment low temperature
	Over-current discharge	Environment over temperature
	Mos over temperature	
Protection	Cell over-charge voltage	Cell charge over temperature
	Cell over-discharge voltage	Cell discharge low temperature
	Pack over-charge voltage	Cell discharge over temperature
	Pack over-discharge voltage	Environment low temperature
	Over-current charge	Environment over temperature
	Over-current discharge	Short circuit
	Mos over temperature	Fault
	Cell charge low temperature	
Others	Cell balance function	
	Communicate function	
	Total capacity function	
	Storage history function	
	Current limiting function	
	Dry contact function	

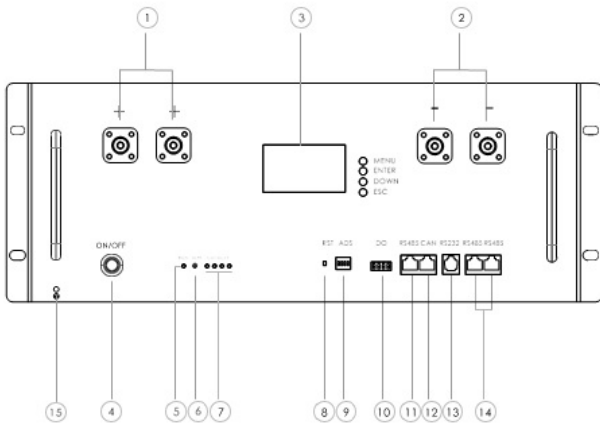

No.	Items	Description
1	+ Power terminal	Power cable terminals: one connect to equipment, the other one paralleling to other battery module for capacity expanding
2	- Power terminal	
3	LCD Screen	Display the battery's data
4	Power Switch	To turn ON/OFF while battery
5	Working indicator light	Display state information
6	ALM alarm indicator light	Red-trouble-light on
7	Capacity volume indicator	Display the battery's capacity
8	Reset Key	Sleep /Activation /Reset

9	ADS Dialer	4 ADD switches, to definite different address code for each battery module when multiple modules are cascaded, up to 15 addresses.
10	Dry Contact Terminal	1/2 Normally open, closed during fault protection; 3/4 Normally open, closed when a low battery alarm
11	RS485	RJ45 Port,used to connect to the inverter's RS485 port

12	CAN	RJ45 Port,used to connect to the inverter's CAN port
13	RS232	RJ11 Port,used battery condition monitoring or manufacturer to debug or service
14/15	RS485	RJ45 Port,used communication in parallel
16	Grounding Point	Safety